

HTH20.10

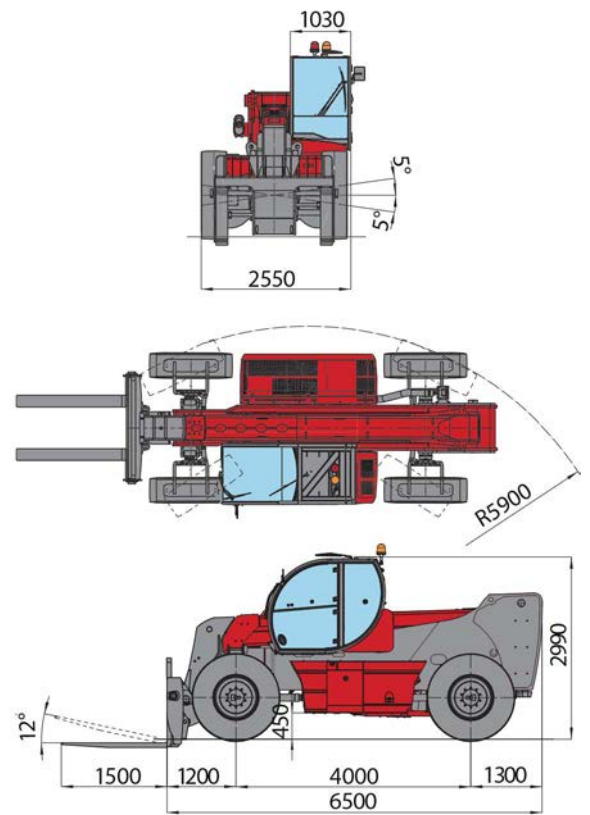

Load chart forklift with forks positioner

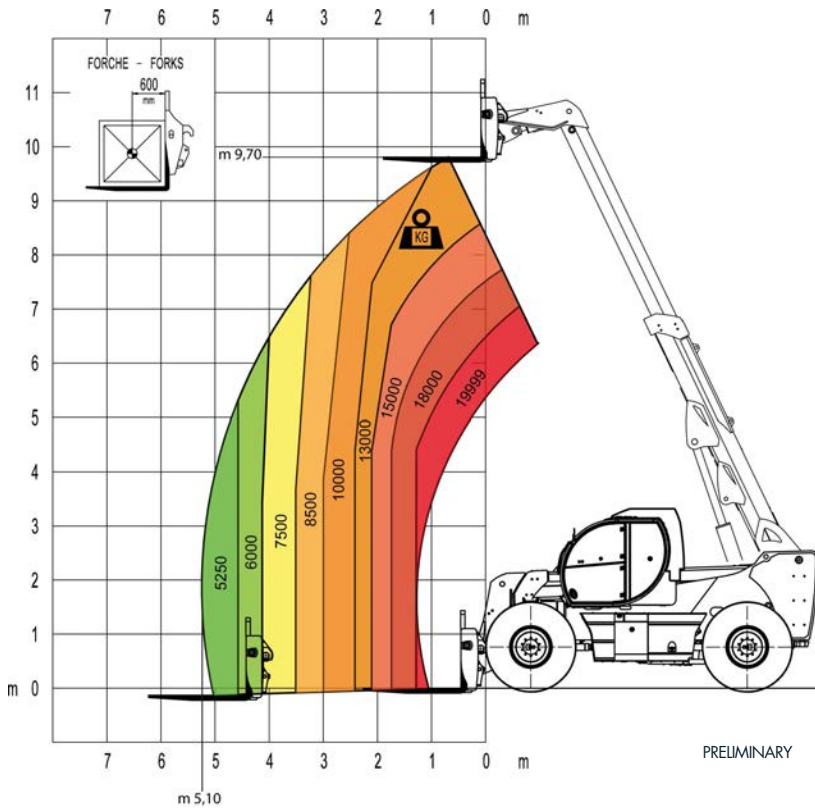

Clamp for wheels handling, with a capacity up to 8.000 kg from 24 to 63 inches.

- MAGNI patented quick fit of the attachment
- Attachments automatic recognition RFID system



LIFT CAPACITY	19.999 Kg at 600 mm load center
MAXIMUM LIFTING HEIGHT	9,70 m
MAXIMUM REACH	5,10m
FORKS	Fork carriage 2.150 mm length Forks 200x90x1.500m
CAB	FOPS-ROPS tested hermetic cab with protectors Front, rear and upper wiper Headlights for road circulation, flashing beaco Rear view mirrors Heating - Air conditioning
CONTROLS	Multi-function electro proportional joystick
BRAKE SYSTEM	Hydraulic servo-assisted multidisc brake in oil bath on both axles, with double circuit Negative parking brake
ENGINE	Mercedes OM 934 LA Euro 4 Final Turbo intercooler 4 cylinders / 5.130 cm ³ Power 175 HP - 129 kW Max rpm = 2.200 Max torque 750 Nm from 1.200 rpm to 1.600 rpm Electronic injection (single pump each injector) Liquid cooling system
AXLES	Heavy Duty with 4-stage epicyclic reduction One steering cylinder each axle Levelling correction front axle at + 5° on the right and +5° on the left 3 types of steering: - with front steering - with round steer - with crab steering Tilting rear axle
PERFORMANCE	Max. travel speed: 25 km/h Drawbar pull: - Gradeability: 34% Turning radius: 5.900 mm
WEIGHTS	Total unladen: 23.000 kg Front axle unladen (boom retracted and lowered): 8.700 kg Rear axle unladen (boom retracted and lowered): 14.300 kg
TRANSMISSION	Rexroth hydrostatics Variable displacement hydrostatic pump with electronic control One variable displacement hydrostatic motor Hydraulic gearbox with 2 speeds forward / reverse
HYDRAULIC CIRCUIT	Load sensing piston pump Circuit at 350 bar Rexroth Proportional hydraulic distributor Suction and return line filter High pressure flexible hose
TANKS CAPACITIES	Engine oil = 16 l Colling liquid = 20 l Hydraulic oil tank = 210 l Fuel tank = 200 l
TYRES DIMENSIONS	16,00 - R25 two each axle, driving and steering
SAFETY	Electronic safety system which controls the load with definition of the lifted load, radius and comparison with the diagrams st red. Block of aggravating movements of the load. Safety valves on cylinders

The data in this brochure are informative and subject to change without notice